



**2018 2<sup>nd</sup> International Conference  
on Electrical Engineering & Informatics**

# **PROCEEDINGS**

**“Toward the Most Efficient Way of Making  
and Dealing with Future Electrical  
Power System and Big Data Analysis”**

**IEEE Catalog Number: CFP18RPC-ART**

**ISBN : 978-1-5386-6000-3**

**16<sup>th</sup> – 17<sup>th</sup> October 2018, Batam - Indonesia**



Organized by

Department of Electrical Engineering  
Faculty of Engineering  
Universitas Riau, Indonesia

Technical Co-Sponsor :





*International Conference on Electrical Engineering and Informatics*

# **PROCEEDINGS**

The 2018 2<sup>nd</sup> International Conference on Electrical Engineering and Informatics

“Toward the Most Efficient Way of Making and Dealing with Future Electrical Power System and Big Data Analysis”

Batam, Indonesia  
October 16<sup>th</sup> – 17<sup>th</sup>, 2018

# Copyright

---

## Copyright and Reprint Permission

2018 2<sup>nd</sup> International Conference on Electrical Engineering and Informatics (ICon EEI 2018)

Nagoya Hill Hotel, Batam, Indonesia, 16<sup>th</sup> – 17<sup>th</sup> October 2018

Copyright and Reprint Permission: Abstracting is permitted with credit to the source. Libraries are permitted to photocopy beyond the limit of U.S. copyright law for private use of patrons those articles in this volume that carry a code at the bottom of the first page, provided the per-copy fee indicated in the code is paid through Copyright Clearance Center, 222 Rosewood Drive, Danvers, MA 01923.

For reprint or republication permission, email to IEEE Copyrights Manager at [pubs-permissions@ieee.org](mailto:pubs-permissions@ieee.org). All rights reserved. Copyright ©2018 by IEEE.

IEEE catalog number: CFP18RPC-ART .

ISBN: 978-1-5386-6000-3

Copyright ©2018 by Institute of Electrical and Electronics Engineers, Inc. All rights reserved

## Conference Information

---

Conference Name 2018 2<sup>nd</sup> International Conference on Electrical Engineering and Informatics (ICon EEI 2018)

Conference Logo



IEEE Conference ID #44554

Dates October 16<sup>th</sup> (Tuesday) – 17<sup>th</sup> (Wednesday) October 2018

Host and Organizer Department of Electrical Engineering  
Faculty of Engineering  
Universitas Riau, Indonesia

Technical co-sponsor IEEE Indonesia Section  
IEEE Communications Society Indonesia Chapter

Venue Nagoya Hill Hotel, Jl. Teuku Umar, Superblok Nagoya Hill Batam,  
Kepulauan Riau, Indonesia

Dates October 16<sup>th</sup> (Tuesday) – 17<sup>th</sup> (Wednesday) October 2018

Official Language English

Secretariat Department of Electrical Engineering, Faculty of Engineering,  
Universitas Riau

Kampus Bina Widya Jalan HR Soebrantas Km 12.5

Pekanbaru, Riau, Indonesia

Phone +62 761-66595

Fax. +62 761-66596

Website [ee.ft.unri.ac.id](http://ee.ft.unri.ac.id)

Email [ee.ft@unri.ac.id](mailto:ee.ft@unri.ac.id)

## **Copyright and Reprint Permission**

2018 2<sup>nd</sup> International Conference on Electrical Engineering and Informatics (ICon EEI 2018)

Nagoya Hill Hotel, Batam, Indonesia, 16<sup>th</sup> – 17<sup>th</sup> October 2018

Copyright and Reprint Permission: Abstracting is permitted with credit to the source. Libraries are permitted to photocopy beyond the limit of U.S. copyright law for private use of patrons those articles in this volume that carry a code at the bottom of the first page, provided the per-copy fee indicated in the code is paid through Copyright Clearance Center, 222 Rosewood Drive, Danvers, MA 01923.

For reprint or republication permission, email to IEEE Copyrights Manager at [pubs-permissions@ieee.org](mailto:pubs-permissions@ieee.org). All rights reserved. Copyright ©2018 by IEEE.

IEEE catalog number: CFP18RPC-ART .  
ISBN: 978-1-5386-6000-3

Copyright ©2018 by Institute of Electrical and Electronics Engineers, Inc. All rights reserved

## Committees

### Advisory Board

<b>Aras Mulyadi</b>	Universitas Riau, Indonesia
<b>Ari Sandyavitri</b>	Universitas Riau, Indonesia
<b>Kohei Aray</b>	Saga University, Japan
<b>Rinaldi Dalimi</b>	Dewan Energi Nasional, Indonesia
<b>Zainal A. Hasibuan</b>	APTIKOM, Indonesia
<b>Tharek Abd. Rahman</b>	Universiti Teknologi Malaysia
<b>Mohd. Wazir Mustafa</b>	Universiti Teknologi Malaysia
<b>Adit Kurniawan</b>	Institut Teknologi Bandung
<b>Fitri Yuli Zulkifli</b>	IEEE Indonesia Section Chair
<b>Khoirul Anwar</b>	Telkom University, Indonesia
<b>Yusnita Rahayu</b>	General Chair of ICon EEI 2016

### Organizing Committee

#### General Chair

<b>Iswadi Hasyim Rosma</b>	Universitas Riau, Indonesia
----------------------------	-----------------------------

#### General Co-Chair

<b>Feri Candra</b>	Universitas Riau, Indonesia
--------------------	-----------------------------

#### Treasurer and Finance Chair

<b>Fri Murdiya</b>	Universitas Riau, Indonesia
--------------------	-----------------------------

#### Technical Program Chair

<b>Dewi Nasien</b>	Universitas Riau, Indonesia
--------------------	-----------------------------

#### Technical Program Co-Chair

<b>Indra Yasri</b>	Universitas Riau, Indonesia
--------------------	-----------------------------

#### Publication Chair

<b>Azriyenni Azhari Zakri</b>	Universitas Riau, Indonesia
-------------------------------	-----------------------------

#### International Liaison Chair

<b>Yusnita Rahayu</b>	Universitas Riau, Indonesia
-----------------------	-----------------------------

## Website and Social Media Chair

<b>Salhazan Nasution</b>	Universitas Riau, Indonesia
<b>Ardi Nugraha</b>	Universitas Riau, Indonesia
<b>Rahmat Rizal</b>	Universitas Riau, Indonesia

## Technical Program Committee

### Chair

<b>Dewi Nasien</b>	Universitas Riau, Indonesia
--------------------	-----------------------------

### Co-Chair

<b>Indra Yasri</b>	Universitas Riau, Indonesia
--------------------	-----------------------------

### Member

<b>Hussein Shareef</b>	College of Engineering United Arab Emirate University, UEA
<b>Abubakar Abdulkarim</b>	University of Ilorin, Nigeria
<b>Ade Gafar Abdullah</b>	Universitas Pendidikan Indonesia, Indonesia
<b>Adrianti Nasir</b>	Universitas Andalas, Indonesia
<b>Azriyenni Azhari Zakri</b>	Universitas Riau, Indonesia
<b>Alex Wenda</b>	UIN Riau, Indonesia
<b>Bernardi Pranggono</b>	Sheffield Hallam University, UK
<b>Bowen Zhou</b>	Northeastern University, China
<b>Jasrul Jamani Jamian</b>	Universiti Teknologi Malaysia, Malaysia
<b>Jafaru Usman</b>	University of Maiduguri, Nigeria
<b>Beenish Sultana</b>	NED University of Engineering & Technology, Pakistan
<b>Dahliyusmanto</b>	Universitas Riau, Indonesia
<b>Feri Candra</b>	Universitas Riau, Indonesia
<b>Fri Murdiya</b>	Universitas Riau, Indonesia
<b>Hamzah Eteruddin</b>	Universitas Lancang Kuning, Indonesia
<b>Harris Simaremare</b>	UIN Riau, Indonesia
<b>Iswadi Hasyim Rosma</b>	Universitas Riau, Indonesia

<b>Iwantono Bermawi</b>	Universitas Riau, Indonesia
<b>Muhammad Syamsu Iqbal</b>	Universitas Mataram, Indonesia
<b>Muhammad Yusuf</b>	Universitas Trunojoyo, Indonesia
<b>Norhashimah b Mohd Saad</b>	Universiti Teknikal Malaysia Melaka, Malaysia
<b>Yanuar Zulardiansyah</b>	Universiti Malaysia Serawak, Malaysia
<b>Yessi Jusman</b>	Universitas Abdurrab, Indonesia
<b>Yusnita Rahayu</b>	Universitas Riau, Indonesia

## Local Arrangement Committee

### Secretariat

<b>Noveri L. Marpaung</b>	Universitas Riau, Indonesia
<b>Linna Okta Sari</b>	Universitas Riau, Indonesia

### Registration Desk

<b>Feranita</b>	Universitas Riau, Indonesia
<b>Ery Safrianti</b>	Universitas Riau, Indonesia

### Events and Location

<b>Budhi Anto</b>	Universitas Riau, Indonesia
<b>Febrizal</b>	Universitas Riau, Indonesia
<b>Irsan Taufik Ali</b>	Universitas Riau, Indonesia

### Documentation

<b>Dian Yayan Sukma</b>	Universitas Riau, Indonesia
<b>Eddy Hamdani</b>	Universitas Riau, Indonesia

### Equipment

<b>Rahyul Amri</b>	Universitas Riau, Indonesia
<b>Dedi Permana</b>	Universitas Riau, Indonesia
<b>Jatwoko</b>	Universitas Riau, Indonesia
<b>Ramdani</b>	Universitas Riau, Indonesia

### Transportation

<b>Firdaus</b>	Universitas Riau, Indonesia
<b>Edy Ervianto</b>	Universitas Riau, Indonesia
<b>Nurhalim</b>	Universitas Riau, Indonesia

### Secretariat

<b>Dahliyusmanto</b>	Universitas Riau, Indonesia
<b>Amir Hamzah</b>	Universitas Riau, Indonesia
<b>Suwitno</b>	Universitas Riau, Indonesia



Authors	Session title	Title	Page
<b>A</b>			
Abinash Gaya	Electronics, Control System and Telecommunication	Performance Analysis of a Dielectric Resonator Antenna with Different Feeding Technique for 5G Communication	92
Abubakar Abdulkarim	Electrical Power System, Renewable Energy and High Voltage Engineering	Analysis of Single Axis Sun Tracker System to Increase Solar Photovoltaic Energy Production in the Tropics	183
Achmad Hidayatno	Informatics, Computer Science, Computer Engineering, Information Technology	Design of Smart Open Parking Using Background Subtraction in the IoT Architecture	7
Adit Kurniawan	Electronics, Control System and Telecommunication	New Design of High-Gain Beam-Steerable Dipole Antenna Array for 5G Smartphone Applications	114
Aghus Sofwan	Electronics, Control System and Telecommunication	Measurement Design of Sensor Node for Landslide Disaster Early Warning System	86
Aghus Sofwan	Informatics, Computer Science, Computer Engineering, Information Technology	Design of Smart Open Parking Using Background Subtraction in the IoT Architecture	7
Ahmad Romadan	Electronics, Control System and Telecommunication	New Design of High-Gain Beam-Steerable Dipole Antenna Array for 5G Smartphone Applications	114
Akbarizan Akbarizan	Informatics, Computer Science, Computer Engineering, Information Technology	Using Bayesian Network for Determining the Recipient of Zakat in BAZNAS Pekanbaru	12
Ali Akbar	Informatics, Computer Science, Computer Engineering, Information Technology	Development of E-Commerce Applications Based on RAD Methods for MSMEs Furniture Business in Central Java	75
Amarilis Yanuarifiani	Informatics, Computer Science, Computer Engineering, Information Technology	Building Domain Ontology from Semi-formal Modelling Language: BPMN	57
Amir Hamzah	Electrical Power System, Renewable Energy and High Voltage Engineering	Web Based Wind Energy Conversion System Monitoring	179
Amir Hamzah	Electrical Power System, Renewable Energy and High Voltage Engineering	Design and Analysis of Variable-Reluctance Stepping Motor as Actuator Element of New Type Automatic Transfer Switch	165
Amun Amri	Electrical Power System, Renewable Energy and High Voltage Engineering	Barrier Discharge In Magnetic Field: The Effect of Magnet Position Induced Discharge in the Gap	175

Authors	Session title	Title	Page
Anhar Anhar	Electronics, Control System and Telecommunication	A Survey on Medium Access Control (MAC) for Clustering Wireless Sensor Network	125
Aqeel S. Jaber	Electrical Power System, Renewable Energy and High Voltage Engineering	Short Term Load Forecasting for Electrical Dispatcher of Baghdad City Based on SVM-PSO Method	140
Ari Sandhyavitri	Electronics, Control System and Telecommunication	Early Warning Systems Using Fire Sensors, Wireless and SMS Technology	108
Aslimeri MT	Electrical Power System, Renewable Energy and High Voltage Engineering	Optimum Torque Control of Stand Alone Wind Turbine Generator System Fed Single Phase Boost Inverter	148
Auliya Syaf	Informatics, Computer Science, Computer Engineering, Information Technology	Comparison of the Effectiveness of Certainty Factor VS Dempster-Shafer in the Determination of the Adolescent Learning Styles	46
Ayuamira Zahari	Electrical Power System, Renewable Energy and High Voltage Engineering	The Effect of Pressure and Gap Distance to AC Breakdown Behavior of SF6/N2 Gas Mixtures	144
Azhagumurugan R	Electronics, Control System and Telecommunication	FEXT Analysis and Its Mitigation Using Double-slit Complementary Split-Ring Resonators	98
Azmi Saleh	Electrical Power System, Renewable Energy and High Voltage Engineering	Comparison of MPPT Fuzzy Logic Controller Based on Perturb and Observe (P&O) and Incremental Conductance (Inc) Algorithm	154
Azriyenni Azhari Zakri	Electrical Power System, Renewable Energy and High Voltage Engineering	Analysis of Single Axis Sun Tracker System to Increase Solar Photovoltaic Energy Production in the Tropics	183
Azriyenni Azhari Zakri	Electrical Power System, Renewable Energy and High Voltage Engineering	Extract Fault Signal via DWT and Penetration of SVM for Fault Classification at Power System Transmission	191
<b>B</b>			
Barri Anand	Electrical Power System, Renewable Energy and High Voltage Engineering	The Implementation and Analysis of Dual Axis Sun Tracker System to Increase Energy Gain of Solar Photovoltaic	187
Bayu Chaniago	Electrical Power System, Renewable Energy and High Voltage Engineering	Web Based Wind Energy Conversion System Monitoring	179
Boy Ihsan	Electrical Power System, Renewable Energy and High Voltage Engineering	Extract Fault Signal via DWT and Penetration of SVM for Fault Classification at Power System Transmission	191

Authors	Session title	Title	Page
Budhi Anto	Electrical Power System, Renewable Energy and High Voltage Engineering	The Implementation and Analysis of Dual Axis Sun Tracker System to Increase Energy Gain of Solar Photovoltaic	187
Budhi Anto	Electrical Power System, Renewable Energy and High Voltage Engineering	Barrier Discharge In Magnetic Field: The Effect Of Magnet Position Induced Discharge In The Gap	175
Budhi Anto	Electrical Power System, Renewable Energy and High Voltage Engineering	Design and Analysis of Variable-Reluctance Stepping Motor as Actuator Element of New Type Automatic Transfer Switch	165

## D

Dadang Redantan	Electrical Power System, Renewable Energy and High Voltage Engineering	Analysis of Peltier Characteristic and Cold Side Treatment for Thermoelectric Generator Module at Brick Kiln Furnace	134
Dedy Fermana	Electronics, Control System and Telecommunication	Early Warning Systems Using Fire Sensors, Wireless and SMS Technology	108
Delsavonita Delsavonita	Informatics, Computer Science, Computer Engineering, Information Technology	Off-line Handwritten Korean Letter Using Principle Component Analysis and Back Propagation Neural Network	72
Deni Yulianti	Informatics, Computer Science, Computer Engineering, Information Technology	New Feature Vector from Freeman Chain Code for Handwritten Roman Character Recognition	67
Deni Yulianti	Informatics, Computer Science, Computer Engineering, Information Technology	Off-line Handwritten Korean Letter Using Principle Component Analysis and Back Propagation Neural Network	72
Dewi Nasien	Informatics, Computer Science, Computer Engineering, Information Technology	New Feature Vector from Freeman Chain Code for Handwritten Roman Character Recognition	67
Dewi Nasien	Informatics, Computer Science, Computer Engineering, Information Technology	Virtual World Environment Design for Vidyanusa e-Learning System	51
Dewi Nasien	Informatics, Computer Science, Computer Engineering, Information Technology	Intelligent Decision Support System Using Certainty Factor Method for Selection Student Career	18
Dewi Nasien	Informatics, Computer Science, Computer Engineering, Information Technology	Off-line Handwritten Korean Letter Using Principle Component Analysis and Back Propagation Neural Network	72
Dian Yayan Sukma	Electrical Power System, Renewable Energy and High Voltage Engineering	Analysis of Single Axis Sun Tracker System to Increase Solar Photovoltaic Energy Production in the Tropics	183

Authors	Session title	Title	Page
Diki Arisandi	Informatics, Computer Science, Computer Engineering, Information Technology	Comparison of the Effectiveness of Certainty Factor VS Dempster-Shafer in the Determination of the Adolescent Learning Styles	46
Dini Nurmalasari	Informatics, Computer Science, Computer Engineering, Information Technology	Social Media Sentiment Analysis Using K-Means and Naïve Bayes Algorithm	24
<b>E</b>			
Eddy Hamdani	Electrical Power System, Renewable Energy and High Voltage Engineering	Barrier Discharge In Magnetic Field: The Effect Of Magnet Position Induced Discharge In The Gap	175
Eddy Hamdani	Electrical Power System, Renewable Energy and High Voltage Engineering	Design and Analysis of Variable-Reluctance Stepping Motor as Actuator Element of New Type Automatic Transfer Switch	165
Edy Ervianto	Electrical Power System, Renewable Energy and High Voltage Engineering	Barrier Discharge In Magnetic Field: The Effect Of Magnet Position Induced Discharge In The Gap	175
Eko Handoyo	Informatics, Computer Science, Computer Engineering, Information Technology	Design of Smart Open Parking Using Background Subtraction in the IoT Architecture	7
Ery Safrianti	Electrical Power System, Renewable Energy and High Voltage Engineering	Analysis of Single Axis Sun Tracker System to Increase Solar Photovoltaic Energy Production in the Tropics	183
Ery Safrianti	Electronics, Control System and Telecommunication	Microstrip Antenna Design H-Shaped Planar Array 4 Elements Using Circular Slot for Fixed WiMAX Network 3.5 GHz Frequency	119
<b>F</b>			
Febrizal Ujang	Electronics, Control System and Telecommunication	A Single DD-MZM for Generating Vestigial Sideband Modulation Scheme in Radio over Fiber Systems	130
Febrizal Ujang	Electronics, Control System and Telecommunication	A Survey on Medium Access Control (MAC) for Clustering Wireless Sensor Network	125
Feoni Yulia	Informatics, Computer Science, Computer Engineering, Information Technology	Social Media Sentiment Analysis Using K-Means and Naïve Bayes Algorithm	24
Feranita Jalil	Electronics, Control System and Telecommunication	Microstrip Antenna Design H-Shaped Planar Array 4 Elements Using Circular Slot for Fixed WiMAX Network 3.5 GHz Frequency	119
Feri Candra	Informatics, Computer Science, Computer Engineering, Information Technology	Off-line Handwritten Korean Letter Using Principle Component Analysis and Back Propagation Neural Network	72

Authors	Session title	Title	Page
Fri Murdiya	Electrical Power System, Renewable Energy and High Voltage Engineering	Application of Molecular Dynamics Study and Homo Lumo Calculation on the Ionized Air for High Voltage Engineering	171
Fri Murdiya	Electrical Power System, Renewable Energy and High Voltage Engineering	Barrier Discharge In Magnetic Field: The Effect Of Magnet Position Induced Discharge In The Gap	175
Fri Murdiya	Electrical Power System, Renewable Energy and High Voltage Engineering	Design and Analysis of Variable-Reluctance Stepping Motor as Actuator Element of New Type Automatic Transfer Switch	165
<b>G</b>			
Gunawan Wibisono	Electronics, Control System and Telecommunication	A Single DD-MZM for Generating Vestigial Sideband Modulation Scheme in Radio over Fiber Systems	130
Gustientiedina Gustientiedina	Informatics, Computer Science, Computer Engineering, Information Technology	Intelligent Decision Support System Using Certainty Factor Method for Selection Student Career	18
<b>H</b>			
Haji Gussyafri	Electrical Power System, Renewable Energy and High Voltage Engineering	Web Based Wind Energy Conversion System Monitoring	179
Hidayat Zainuddin	Electrical Power System, Renewable Energy and High Voltage Engineering	The Effect of Pressure and Gap Distance to AC Breakdown Behavior of SF6/N2 Gas Mixtures	144
Hikmah Putra	Electronics, Control System and Telecommunication	New Design of High-Gain Beam-Steerable Dipole Antenna Array for 5G Smartphone Applications	114
<b>I</b>			
Ichsan Maulana Putra	Electrical Power System, Renewable Energy and High Voltage Engineering	Analysis of Single Axis Sun Tracker System to Increase Solar Photovoltaic Energy Production in the Tropics	183
Iis Afrianty	Informatics, Computer Science, Computer Engineering, Information Technology	The Effect of Class Imbalance Against LVQ Classification	42
Iswadi Hasyim Rosma	Electrical Power System, Renewable Energy and High Voltage Engineering	Analysis of Single Axis Sun Tracker System to Increase Solar Photovoltaic Energy Production in the Tropics	183
Iswadi Hasyim Rosma	Electrical Power System, Renewable Energy and High Voltage Engineering	The Implementation and Analysis of Dual Axis Sun Tracker System to Increase Energy Gain of Solar Photovoltaic	187
Iswadi Hasyim Rosma	Electrical Power System, Renewable Energy and High Voltage Engineering	Extract Fault Signal via DWT and Penetration of SVM for Fault Classification at Power System Transmission	191

Authors	Session title	Title	Page
Iswadi Hasyim Rosma	Electrical Power System, Renewable Energy and High Voltage Engineering	Web Based Wind Energy Conversion System Monitoring	179
Iwan Kurniawan	Electrical Power System, Renewable Energy and High Voltage Engineering	Web Based Wind Energy Conversion System Monitoring	179
<b>J</b>			
Jafaru Usman	Electrical Power System, Renewable Energy and High Voltage Engineering	Extract Fault Signal via DWT and Penetration of SVM for Fault Classification at Power System Transmission	191
Jamaludin Mohd Wari	Electrical Power System, Renewable Energy and High Voltage Engineering	The Effect of Pressure and Gap Distance to AC Breakdown Behavior of SF6/N2 Gas Mixtures	144
Jamarrintan Asmawi	Electrical Power System, Renewable Energy and High Voltage Engineering	The Implementation and Analysis of Dual Axis Sun Tracker System to Increase Energy Gain of Solar Photovoltaic	187
<b>K</b>			
Kasman Rukun	Informatics, Computer Science, Computer Engineering, Information Technology	Intelligent Decision Support System Using Certainty Factor Method for Selection Student Career	18
Kusuma Ayu Laksitowening	Informatics, Computer Science, Computer Engineering, Information Technology	Building Domain Ontology from Semi-formal Modelling Language: BPMN	57
<b>L</b>			
Lasminiasih Lasminiasih	Informatics, Computer Science, Computer Engineering, Information Technology	Development of E-Commerce Applications Based on RAD Methods for MSMEs Furniture Business in Central Java	75
Linna Oktaviana Sari	Electronics, Control System and Telecommunication	Microstrip Antenna Design H-Shaped Planar Array 4 Elements Using Circular Slot for Fixed WiMAX Network 3.5 GHz Frequency	119
Linna Oktaviana Sari	Informatics, Computer Science, Computer Engineering, Information Technology	Virtual World Environment Design for Vidyanusa e-Learning System	51
<b>M</b>			
M Arfan	Informatics, Computer Science, Computer Engineering, Information Technology	Design of Smart Open Parking Using Background Subtraction in the IoT Architecture	7
M. Hasmil Adiya	Informatics, Computer Science, Computer Engineering, Information Technology	New Feature Vector from Freeman Chain Code for Handwritten Roman Character Recognition	67

Authors	Session title	Title	Page
M. Hasmil Adiya	Informatics, Computer Science, Computer Engineering, Information Technology	Off-line Handwritten Korean Letter Using Principle Component Analysis and Back Propagation Neural Network	72
Maman Somantri	Informatics, Computer Science, Computer Engineering, Information Technology	Design of Smart Open Parking Using Background Subtraction in the IoT Architecture	7
Mardhiyah Kharismayanda	Informatics, Computer Science, Computer Engineering, Information Technology	Tropical Diseases Web-based Expert System Using Certainty Factor	62
Marzieh Yaeghoobi	Electrical Power System, Renewable Energy and High Voltage Engineering	Application of Molecular Dynamics Study and Homo Lumo Calculation on the Ionized Air for High Voltage Engineering	171
Miftah Andriansyah	Informatics, Computer Science, Computer Engineering, Information Technology	Development of E-Commerce Applications Based on RAD Methods for MSMEs Furniture Business in Central Java	75
Missyamsu Algusri	Electrical Power System, Renewable Energy and High Voltage Engineering	Analysis of Peltier Characteristic and Cold Side Treatment for Thermoelectric Generator Module at Brick Kiln Furnace	134
Mochamad Susantok	Electronics, Control System and Telecommunication	Android-based Touch Screen Projector Design Using a 3D Camera	102
Mohd Haizal Jamaluddin	Electronics, Control System and Telecommunication	Performance Analysis of a Dielectric Resonator Antenna with Different Feeding Technique for 5G Communication	92
Mohd Zakree Ahmad Nazri	Informatics, Computer Science, Computer Engineering, Information Technology	Using Bayesian Network for Determining the Recipient of Zakat in BAZNAS Pekanbaru	12
Mohd Zakree Ahmad Nazri	Informatics, Computer Science, Computer Engineering, Information Technology	Tropical Diseases Web-based Expert System Using Certainty Factor	62
Monica Sari Hariyanto	Informatics, Computer Science, Computer Engineering, Information Technology	Design of Smart Open Parking Using Background Subtraction in the IoT Architecture	7
Muhammad Amin Sahari	Informatics, Computer Science, Computer Engineering, Information Technology	A Study on the Effects of Learning Material Towards Information Integrity IN MOODLE Learning Management System (LMS)	81
Muhammad Diono	Electronics, Control System and Telecommunication	Android-based Touch Screen Projector Design Using a 3D Camera	102
Muhammad Ihsan Zul	Informatics, Computer Science, Computer Engineering, Information Technology	Social Media Sentiment Analysis Using K-Means and Naïve Bayes Algorithm	24

Authors	Session title	Title	Page
Muhammad Nasir	Informatics, Computer Science, Computer Engineering, Information Technology	An Analysis of Instructional Design and Evaluation of Physics Learning Media of Three Dimensional Animation Using Blender Application	36
Muhammad Raka Perbawa	Informatics, Computer Science, Computer Engineering, Information Technology	Performance Evaluation of Automatic Dependant Surveillance Broadcast Data Distribution Using Named Data Networking	1
Muhammad Ramlee Kamarudin	Electronics, Control System and Telecommunication	Performance Analysis of a Dielectric Resonator Antenna with Different Feeding Technique for 5G Communication	92
Muhammad Reynaldi	Electronics, Control System and Telecommunication	Measurement Design of Sensor Node for Landslide Disaster Early Warning System	86
Muhammad Saputra	Electronics, Control System and Telecommunication	Android-based Touch Screen Projector Design Using a 3D Camera	102
Muhammad Saufi Kamarudin	Electrical Power System, Renewable Energy and High Voltage Engineering	The Effect of Pressure and Gap Distance to AC Breakdown Behavior of SF6/N2 Gas Mixtures	144
Muhammad Yusa	Electronics, Control System and Telecommunication	Early Warning Systems Using Fire Sensors, Wireless and SMS Technology	108
Mukhlidi Muskhir	Electrical Power System, Renewable Energy and High Voltage Engineering	Optimum Torque Control of Stand Alone Wind Turbine Generator System Fed Single Phase Boost Inverter	148
Muldi Yuhendri	Electrical Power System, Renewable Energy and High Voltage Engineering	Optimum Torque Control of Stand Alone Wind Turbine Generator System Fed Single Phase Boost Inverter	148
<b>N</b>			
Neni Frimayanti	Electrical Power System, Renewable Energy and High Voltage Engineering	Application of Molecular Dynamics Study and Homo Lumo Calculation on the Ionized Air for High Voltage Engineering	171
Noor Azlinda Ahmad	Electrical Power System, Renewable Energy and High Voltage Engineering	Characteristics of Positive Lightning as Observed in Temperate and Tropic Regions: A Review	159
Nor Asrina Ramlee	Electrical Power System, Renewable Energy and High Voltage Engineering	Characteristics of Positive Lightning as Observed in Temperate and Tropic Regions: A Review	159
Novi Yanti	Informatics, Computer Science, Computer Engineering, Information Technology	Tropical Diseases Web-based Expert System Using Certainty Factor	62



Authors	Session title	Title	Page
Nur Farhani Ambo	Electrical Power System, Renewable Energy and High Voltage Engineering	The Effect of Pressure and Gap Distance to AC Breakdown Behavior of SF6/N2 Gas Mixtures	144
Nurcahaya Nurcahaya	Informatics, Computer Science, Computer Engineering, Information Technology	Using Bayesian Network for Determining the Recipient of Zakat in BAZNAS Pekanbaru	12
Nurhalim Dani Ali	Electrical Power System, Renewable Energy and High Voltage Engineering	The Implementation and Analysis of Dual Axis Sun Tracker System to Increase Energy Gain of Solar Photovoltaic	187
Nurhalim Dani Ali	Electronics, Control System and Telecommunication	Early Warning Systems Using Fire Sensors, Wireless and SMS Technology	108
Nurhizam Safie Mohd Satar	Informatics, Computer Science, Computer Engineering, Information Technology	A Study on the Effects of Learning Material Towards Information Integrity IN MOODLE Learning Management System (LMS)	81
<b>O</b>			
Omar Fakhrol Syakirin	Informatics, Computer Science, Computer Engineering, Information Technology	New Feature Vector from Freeman Chain Code for Handwritten Roman Character Recognition	67
Othman Mohd	Informatics, Computer Science, Computer Engineering, Information Technology	A Study on the Effects of Learning Material Towards Information Integrity IN MOODLE Learning Management System (LMS)	81
<b>R</b>			
Raghuraman Selvaraju	Electronics, Control System and Telecommunication	Performance Analysis of a Dielectric Resonator Antenna with Different Feeding Technique for 5G Communication	92
Raghuraman Selvaraju	Electronics, Control System and Telecommunication	Performance Analysis of a Dielectric Resonator Antenna with Different Feeding Technique for 5G Communication	92
Rahmad Abdillah	Informatics, Computer Science, Computer Engineering, Information Technology	The Effect of Class Imbalance Against LVQ Classification	42
Rahmad Kurniawan	Informatics, Computer Science, Computer Engineering, Information Technology	Using Bayesian Network for Determining the Recipient of Zakat in BAZNAS Pekanbaru	12
Rahmad Kurniawan	Informatics, Computer Science, Computer Engineering, Information Technology	Tropical Diseases Web-based Expert System Using Certainty Factor	62
Rahmat Rizal	Informatics, Computer Science, Computer Engineering, Information Technology	Virtual World Environment Design for Vidyanusa e-Learning System	51

Authors	Session title	Title	Page
Rahmat Rizal	Informatics, Computer Science, Computer Engineering, Information Technology	Off-line Handwritten Korean Letter Using Principle Component Analysis and Back Propagation Neural Network	72
Rahyul Amri	Electronics, Control System and Telecommunication	Early Warning Systems Using Fire Sensors, Wireless and SMS Technology	108
Rajagopal Nilavalan	Electronics, Control System and Telecommunication	A Survey on Medium Access Control (MAC) for Clustering Wireless Sensor Network	125
Riri Fitri Sari	Informatics, Computer Science, Computer Engineering, Information Technology	Performance Evaluation of Automatic Dependant Surveillance Broadcast Data Distribution Using Named Data Networking	1
Riri Fitri Sari	Informatics, Computer Science, Computer Engineering, Information Technology	A Review of Firefly Algorithms for Path Planning, Vehicle Routing and Traveling Salesman Problems	30
Riwayani Riwayani	Informatics, Computer Science, Computer Engineering, Information Technology	An Analysis of Instructional Design and Evaluation of Physics Learning Media of Three Dimensional Animation Using Blender Application	36
Rizo Prastowo	Informatics, Computer Science, Computer Engineering, Information Technology	An Analysis of Instructional Design and Evaluation of Physics Learning Media of Three Dimensional Animation Using Blender Application	36
Rooswhan Budi Utomo	Informatics, Computer Science, Computer Engineering, Information Technology	Development of E-Commerce Applications Based on RAD Methods for MSMEs Furniture Business in Central Java	75
<b>S</b>			
Siti Norul Huda Sheikh Abdullah	Informatics, Computer Science, Computer Engineering, Information Technology	Using Bayesian Network for Determining the Recipient of Zakat in BAZNAS Pekanbaru	12
Siti Norul Huda Sheikh Abdullah	Informatics, Computer Science, Computer Engineering, Information Technology	Tropical Diseases Web-based Expert System Using Certainty Factor	62
Sri Murhayati	Informatics, Computer Science, Computer Engineering, Information Technology	Using Bayesian Network for Determining the Recipient of Zakat in BAZNAS Pekanbaru	12
Sumardi Sumardi	Electronics, Control System and Telecommunication	Measurement Design of Sensor Node for Landslide Disaster Early Warning System	86
Suryandari Sedyo Utami	Informatics, Computer Science, Computer Engineering, Information Technology	Development of E-Commerce Applications Based on RAD Methods for MSMEs Furniture Business in Central Java	75

Authors	Session title	Title	Page
Susi Rubiyati	Electronics, Control System and Telecommunication	Android-based Touch Screen Projector Design Using a 3D Camera	102
Suwanto Sanjaya	Informatics, Computer Science, Computer Engineering, Information Technology	The Effect of Class Imbalance Against LVQ Classification	42
Suwitno Suwitno	Electrical Power System, Renewable Energy and High Voltage Engineering	Barrier Discharge In Magnetic Field: The Effect Of Magnet Position Induced Discharge In The Gap	175
Suwitno Suwitno	Electrical Power System, Renewable Energy and High Voltage Engineering	Web Based Wind Energy Conversion System Monitoring	179
Suwitno Suwitno	Electrical Power System, Renewable Energy and High Voltage Engineering	Design and Analysis of Variable-Reluctance Stepping Motor as Actuator Element of New Type Automatic Transfer Switch	165
Syahril Syahril	Informatics, Computer Science, Computer Engineering, Information Technology	Intelligent Decision Support System Using Certainty Factor Method for Selection Student Career	18
Syukri Darmawan	Electrical Power System, Renewable Energy and High Voltage Engineering	The Implementation and Analysis of Dual Axis Sun Tracker System to Increase Energy Gain of Solar Photovoltaic	187
Syukri Darmawan	Electrical Power System, Renewable Energy and High Voltage Engineering	Extract Fault Signal via DWT and Penetration of SVM for Fault Classification at Power System Transmission	191
<b>T</b>			
T. Brenda Chandrawati	Informatics, Computer Science, Computer Engineering, Information Technology	A Review of Firefly Algorithms for Path Planning, Vehicle Routing and Traveling Salesman Problems	30
Teddy Chandra	Informatics, Computer Science, Computer Engineering, Information Technology	New Feature Vector from Freeman Chain Code for Handwritten Roman Character Recognition	67
<b>V</b>			
Vitriani Vitriani	Informatics, Computer Science, Computer Engineering, Information Technology	Intelligent Decision Support System Using Certainty Factor Method for Selection Student Career	18
<b>W</b>			
Wilda Hunafa	Informatics, Computer Science, Computer Engineering, Information Technology	Tropical Diseases Web-based Expert System Using Certainty Factor	62

Authors	Session title	Title	Page
Wita Yulianti	Informatics, Computer Science, Computer Engineering, Information Technology	Comparison of the Effectiveness of Certainty Factor VS Dempster-Shafer in the Determination of the Adolescent Learning Styles	46
<b>Y</b>			
Yahaya Abd Rahim	Informatics, Computer Science, Computer Engineering, Information Technology	A Study on the Effects of Learning Material Towards Information Integrity IN MOODLE Learning Management System (LMS)	81
Yangly Refli	Electrical Power System, Renewable Energy and High Voltage Engineering	Design and Analysis of Variable-Reluctance Stepping Motor as Actuator Element of New Type Automatic Transfer Switch	165
Yanuar Firdaus Arie Wibowo	Informatics, Computer Science, Computer Engineering, Information Technology	Building Domain Ontology from Semi-formal Modelling Language: BPMN	57
Yenny Desnelita	Informatics, Computer Science, Computer Engineering, Information Technology	New Feature Vector from Freeman Chain Code for Handwritten Roman Character Recognition	67
Yenny Desnelita	Informatics, Computer Science, Computer Engineering, Information Technology	Intelligent Decision Support System Using Certainty Factor Method for Selection Student Career	18
Yoga Yusfarino	Electronics, Control System and Telecommunication	Microstrip Antenna Design H-Shaped Planar Array 4 Elements Using Circular Slot for Fixed WiMAX Network 3.5 GHz Frequency	119
Yusnita Rahayu	Electronics, Control System and Telecommunication	New Design of High-Gain Beam-Steerable Dipole Antenna Array for 5G Smartphone Applications	114
<b>Z</b>			
Zulkiflee Abd Rahim	Informatics, Computer Science, Computer Engineering, Information Technology	A Study on the Effects of Learning Material Towards Information Integrity IN MOODLE Learning Management System (LMS)	81

# Barrier Discharge In Magnetic Field: The Effect Of Magnet Position Induced Discharge In The Gap

Fri Murdiya  
Dept. Electrical Engineering  
Universitas Riau  
Pekanbaru, Indonesia  
frimurdiya@eng.unri.ac.id

Suwitno  
Dept. Electrical Engineering  
Universitas Riau  
Pekanbaru, Indonesia  
suwitnoanisa@gmail.com

Budhi Anto  
Dept. Electrical Engineering  
Universitas Riau  
Pekanbaru, Indonesia  
budhianto@eng.unri.ac.id

Edy Evrianto  
Dept. Electrical Engineering  
Universitas Riau  
Pekanbaru, Indonesia  
edyevrianto@gmail.com

Eddy Hamdani  
Dept. Electrical Engineering  
Universitas Riau  
Pekanbaru, Indonesia  
ehamdani@eng.unri.ac.id

Amun Amri  
Dept. Chemical Engineering  
Universitas Riau  
Pekanbaru, Indonesia  
amun.amri@eng.unri.ac.id

**Abstract**— The study of the effect permanent magnet (PM) position induced discharge in the gap of Dielectric Barrier Discharge (DBD) was carried out. The PM position influenced the plasma discharge. It is shown that the plasma intensity in the model I was higher than other models. The currents discharge in the model III and IV were higher than model I and II. However, the discharge current in the model II was lower than the model I. The ozone gas was generated for all models. The concentration ozone in the model II and III are higher than model I and IV. It is shown that the plasma progressed in the gap of DBD was influenced by the PM position.

**Keywords**— DBD, Magnetic Field, PM Position, Discharge Current, Ozone Generator

## I. INTRODUCTION

The dielectric barrier discharge (DBD) generator supports the process in many areas such as in physics, medical, chemistry, etc. The components installed in this technology such as high voltage power converter, metal electrodes and solid insulator as dielectric. The electron discharges or gas ionization is the unsuccessful point of the dielectric to be itself as insulator/dielectric. Barrier discharge occurred in the gap between two electrodes and dielectric leads to ionize the gas insulation (air) and it results the ozone molecule. The barrier discharge promotes the micro plasmas in the gap and the eyes can catch them. The dielectric materials were always chosen such as ceramics, mica, glass, acrylic, granite, quartz and nylon,

Osawa and co-workers, and Shimizu and co-worker reported that the application of high voltage barrier discharge technology to produce ozone, sterilization of drinking water and also the destruction of NOx gas compounds from diesel engine smoke [1, 2]. A.A. Abdelaziz and co-workers [3,4] reported the application ozone generator to destruct the dangerous naphthalene material. This experiment used a needle and plane electrode and they were separated by a mica material as dielectric. Peter Luks and co-workers [5] designed a tube electrode with a solid dielectric made of aluminum material

(Al<sub>2</sub>O<sub>3</sub>) to initiate micro discharge in the water. The ac and dc power supplies were commonly used in the high voltage plasma generator to generate the ozone molecules [6,7,8]. There are some configuration of dielectric and electrodes as barrier discharge generator. The dielectric barrier discharge configurations are presented in Fig. 1.

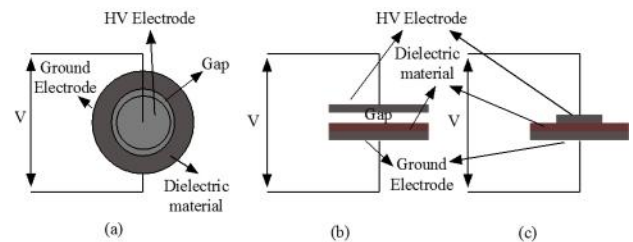

Fig. 1. (a). Cylindrical DBD, (b) Planar DBD, (c) Surface DBD [1,6].

The effect of magnetic field on plasma progress between electrodes and dielectric was investigated by Park. Park used multi needles as high voltage electrodes, which were positioned in the gap between electrode and dielectric [9]. Pakarek investigated the effect of permanent magnet on plasma progress in the gap between a needle electrode and dielectric. The needle electrode position was parallel to the permanent magnet. It is shown that the effect of magnetic field influenced the movement of ionic molecules of gas [10]. Liu initiated a study to investigate the comparison of planar dielectric barrier discharge in the magnetic field and without magnetic field. Liu also concerned on the nanosecond pulse power that was connected to a high voltage electrode. This experiment result was concluded that the plasma progress on solid dielectric that influenced by the magnetic field was slightly different phenomena compare to the planar dielectric barrier discharge without magnetic field [11].

In this research, we proposed to use a tile/ floor ceramic as dielectric for plasma producer in the gap. We also made a comparison on the influence of magnetic field induced plasma

in the gap by varying the permanent magnet position and the conventional dielectric barrier discharge without magnetic field. We chose to install the high voltage power supply (with voltage level of 8 kV and frequency of 25 kHz) that was connected to an anode electrode. We also modified the gap between anode and cathode electrodes by putting a tile on the cathode electrode. The plasma will progress in the gap between anode electrode and dielectric. In order to produce ozone gas, we injected the air into the gap by a mini fan. We recorded the data such as discharge current, plasma photographs for several position of PM and ozone concentration by considering the influence of magnetic field in the DBD and the conventional DBD without magnetic field.

## II. EXPERIMENTAL PROCEDURE

The scheme of experiment is presented in Fig.2. The DBD was designed with the permanent magnet (PM) position under and above electrodes. The positions of PM are presented in Fig.3. Model I is DBD without PM, model II is DBD with PM and the position of PM is under cathode electrode, model II is DBD with two PMs that are above anode electrode and under cathode electrode and they are at attraction condition and model IV is DBD with two PMs that are under and above for each electrode and they are at repulsion condition.

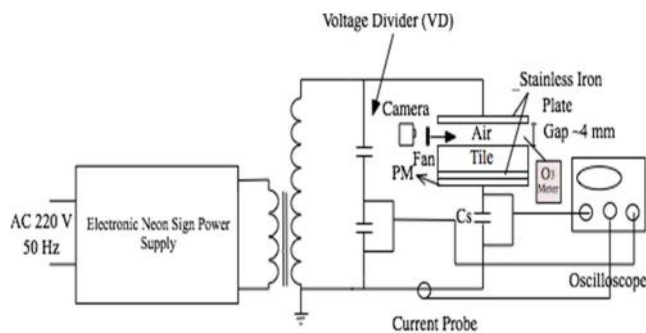

Fig.2 The scheme of DBD test

The magnetic field density of PM is 315 mT and it was measured with FH 51 Tesla Meter. The solid dielectric arranged on cathode electrode was a tile (Platinum made in Indonesia). The dimensions of tile were length of 200mm, width of 200mm and thick of 8mm, respectively. In order to initiate the plasma between anode electrode and solid dielectric, we set the gap distance between them at about 4 mm.

Electronic Neon Sign Power Supply (ENSPS) made in China with output voltage 8 kVrms and frequency 25 kHz was installed in this experiment. The anode and cathode electrodes were connected to ENSPS. The voltage divider (VD) SEW made in Taiwan was equipped on anode termination and it was connected to a digital oscilloscope Hantek 6204 BC. The ratio of VD is 1,000 : 1. The current discharge was measured by a current probe Hantek CC65.

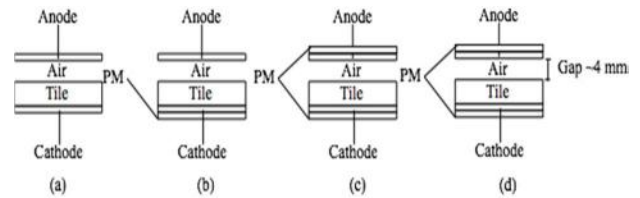

Fig.3. The positions of PM. (a) Model I, (b) Model II, (c) Model III, (d) Model IV.

In this research we also simulated the producing ozone by injection of natural air. We used a mini fan to blow the air into discharge area. The concentration of ozone was recorded by an ozone analyzer HT-E-O3 made in Hongkong.

## III. RESULT AND DISCUSSION

### A. Plasma Pictures

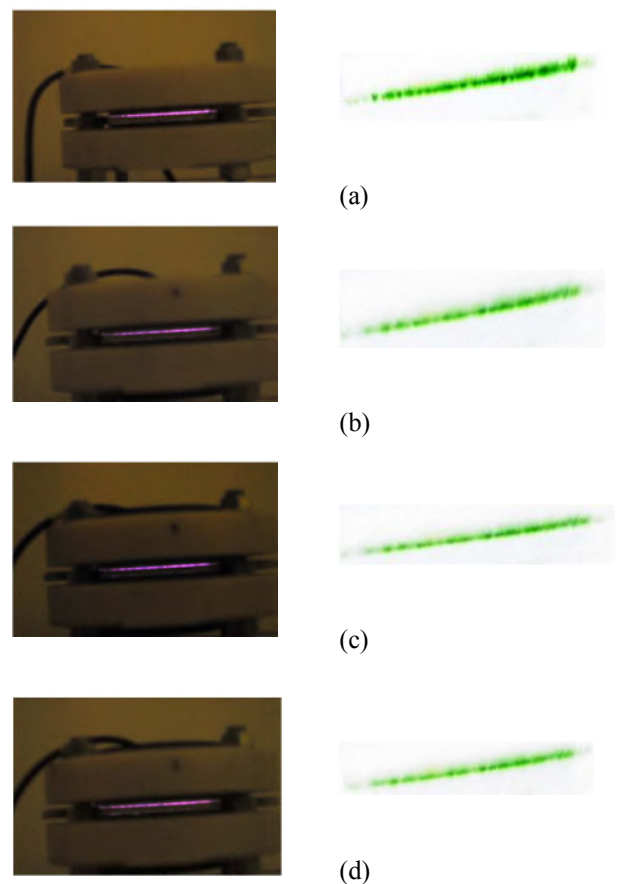

Fig. 4 Plasma Photographs (left side is the real colors and right side is the inverting colors). (a) Model I, (b) Model II, (c) Model III, (d) Model IV.

The plasma pictures are presented in Fig.4. The plasma developed clearly in the gap for all models. Pictures in left side is real photographs. However, the pictures in right side is the inverting color. In the model I, the intensity plasma is slightly higher rather than other models. It was indicated by black color (at right side pictures). The lowest intensity is the model IV.

*B. Voltage and Discharge Current*

The discharge currents and voltage are presented in Fig.5. The discharge current was recorded after several minutes discharge. The discharge current in the model I is higher than model II. However, the discharge current in the model III and IV are higher than model I and II.

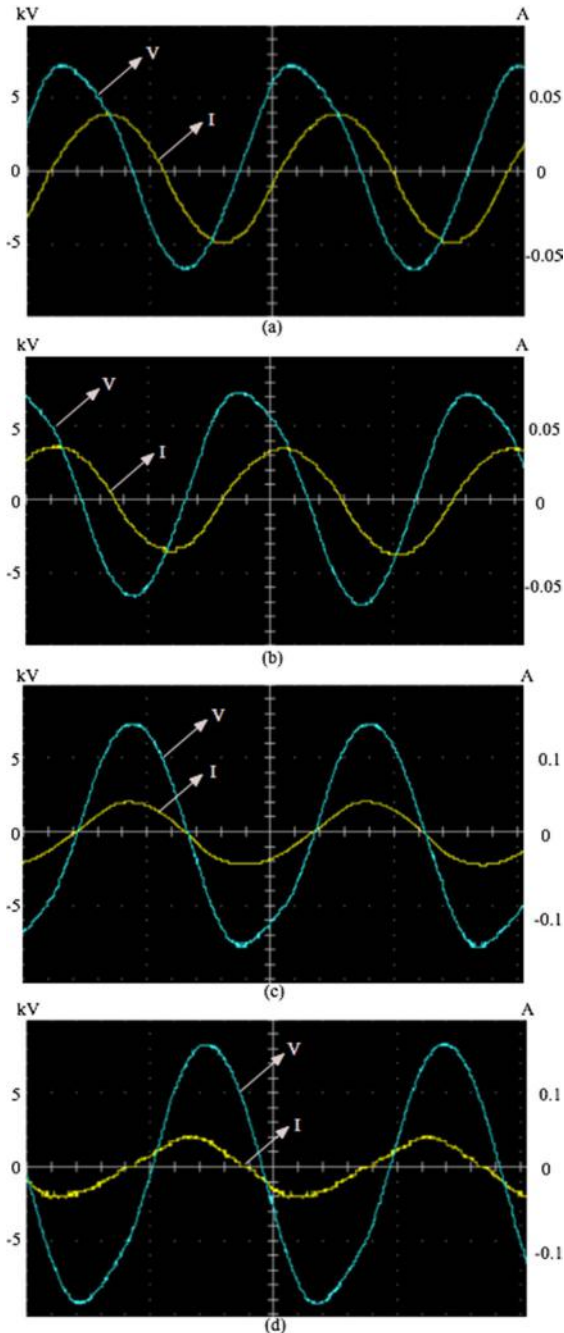

Fig.5 Voltage and discharge current, (a) model I,(b) model II, (c) model III and (d) model IV

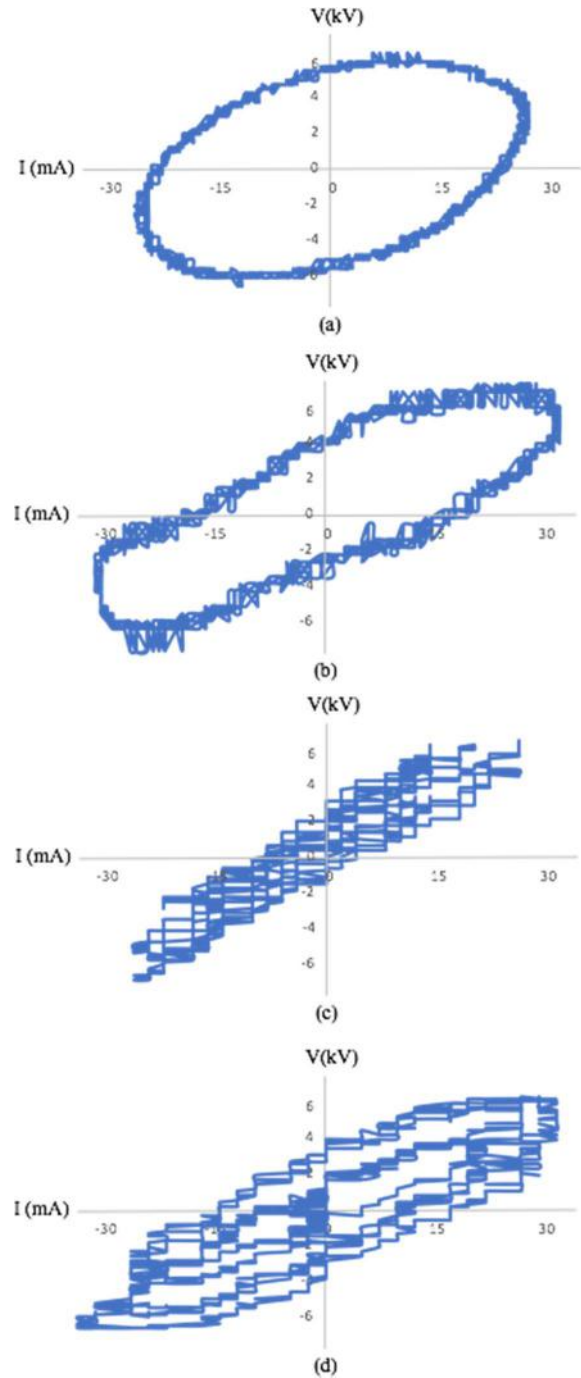

Fig. 6. Lissajous figures. (a) model I,(b) model II, (c) model III and (d) model IV

The Lissajous figures for all models are depicted in Fig.6. These graphs were measured by a digital oscilloscope and current and voltage probe after discharge developed until five minutes. It was difficult to fix these graphs because these discharges were very unstable. It is shown that the lissajous graphs for all models are sharply different. Many aspects should be considered to define the characteristics of dielectric barrier discharge. So that, the next investigation will be needed.

C. Ozone Generation

The ozone generation versus times is shown in Fig. 7. The concentration ozone is in ppm. The model II and III produced ozone are higher than model I and IV at time discharge until 9 minutes. The lowest concentration is model IV.

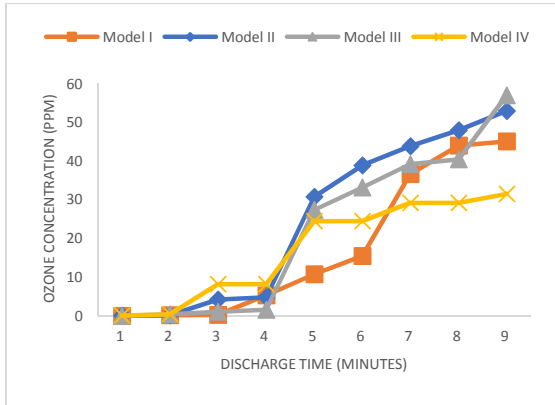

Fig.7 Ozone production for all models.

IV. CONCLUSIONS

There are some summarizes in this investigation such as the plasma can develop in the gap for all models. The intensity plasma in the model I is slightly higher than other models. Next, the discharge current in the model I is slightly higher than model II. However, the discharge currents in the model III and IV are slightly higher than model I. Furthermore, the model II and III produced the ozone gas are slightly higher than model I and IV. Finally, the discharge progressed in the gap of DBD was very unstable for all models.

ACKNOWLEDGMENT

We thank to DIKTI for the financial support through Penelitian Strategis Nasional Institusi year : 2018.

REFERENCES

- [1] N. Osawa, T. Suetomi, Y. Hafuka, T. Shuha, Y. Yoshioka, R. Hanaoka, "Investigation on reactor configuration of non-thermal plasma catalytic hybrid method for NOx removal of diesel engine exhaust", International Journal of Plasma and Environmental Science and Technology, Vol.6, No.2, September 2012.
- [2] K. Shimizu, S. Muramatsu, T. Sonoda, and M. Blajan, "Water treatment by low voltage discharge in water", International Journal of Plasma and Environmental Science and Technology, Vol.4, No.1, March 2010.
- [3] Ayman A Abdelaziz, Takafumi Seto, M Abdel-Salam, Tatsuo Ishijima and Yoshio Otan, "Influence of applied voltage waveforms on the performance of surface dielectric barrier discharge reactor for decomposition of naphthalene", Journal of Physics D: Applied Physics, Volume 48, Number 19, 2015.
- [4] Ayman A Abdelaziz · Takafumi Seto · M Abdel-Salam · Yoshio Otani," Influence of nitrogen excited species on the destruction of naphthalene in nitrogen and air using surface dielectric barrier discharge,"Journal Of Hazardous Materials 246-247c:26-33 · December 2012
- [5] Petr Lukes, Martin Clupek, Vaclav Babicky, and Pavel Sunka, "Pulsed Electrical Discharge in Water Generated Using Porous-Ceramic-Coated Electrodes", IEEE Transactions On Plasma Science, Vol. 36, No. 4, August 2008
- [6] J. Chen and P. Wang, "Effect of Relative Humidity on Electron Distribution and Ozone Production by DC Coronas in Air," TPS. IEEE Transactions on Plasma Science, Vol. 33, pp.808-812, 2005.
- [7] Fri Murdiya, Febrizal Febrizal, Amun Amri," The performance of surface barrier discharge in magnetic field driven by half bridge series resonance converter", [Journal of Mechatronics, Electrical Power, and Vehicular Technology](#), Vol.8, No.2, pp.95-102, Dec. 2017.
- [8] Fri Murdiya, Febrizal, "The performance surface barrier discharge in magnetic field driven by series resonance converter", [2017 6th International Conference on Electrical Engineering and Informatics \(ICEEI\)](#), Langkawi Malaysia,25-27 Nov. 2017
- [9] J.Y Park , G. H. Kim , J. D. Kim , H.S. Koh, D.C. Lee" NOx Removal Using DC Corona Discharge with Magnetic Field" Combustion Science and Technology, Vol. 133 Issue 1-3, pp. 65-77, Taylor & Francis, 1998
- [10] Stanislav Peka rek "Experimental Study of Nitrogen Oxides and Ozone Generation by Corona-Like Dielectric Barrier Discharge with Airflow in a Magnetic Field" Plasma Chem Plasma Process, vol. 37, pp. 1313-1330, Springer, 2017.
- [11] Y. Liu, H. Qi, Z. Fan, C.S. Ren, " The impacts of magnetic field on repetitive nanosecond pulsed dielectric barrier discharge in air ", Physic of Plasmas, Volume 23, 2016.



# CERTIFICATE



International Conference on Electrical Engineering and Informatics

## 2018 2<sup>nd</sup> International Conference on Electrical Engineering and Informatics

October 16<sup>th</sup> - 17<sup>th</sup> 2018 at Nagoya Hill Hotel, Batam, Indonesia

*Hereby acknowledges the participation and contribution of:*

**Dr. Eng. Fri Murdiya, ST., MT.**

**as Invited Speaker**

**Dr. Iswadi Hasyim Rosma**  
General Chair of ICon EEI 2018

